

### Mechanical Data

- Surface Mount Package
- Weight: 0.0014 grams (Approximate)
- Moisture Sensitivity Level 1
- Halogen Free. "Green" Device (Note 1)
- Epoxy Meets UL 94 V-0 Flammability Rating
- Lead Free Finish/RoHS Compliant ("P" Suffix Designates RoHS Compliant. See Ordering Information)

Note:1. free "Green" products are defined as those which contain <900ppm bromine, <900ppm chlorine (<1500ppm total Br + Cl) and <1000ppm antimony compounds.

### Package 3D Photo

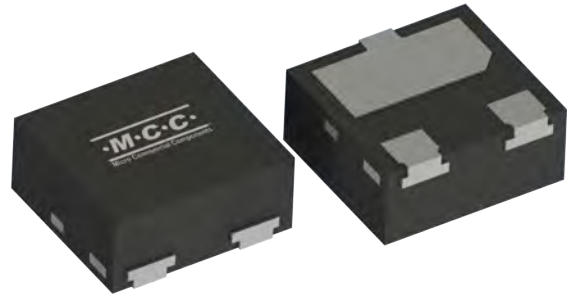

### Package Outline Dimensions

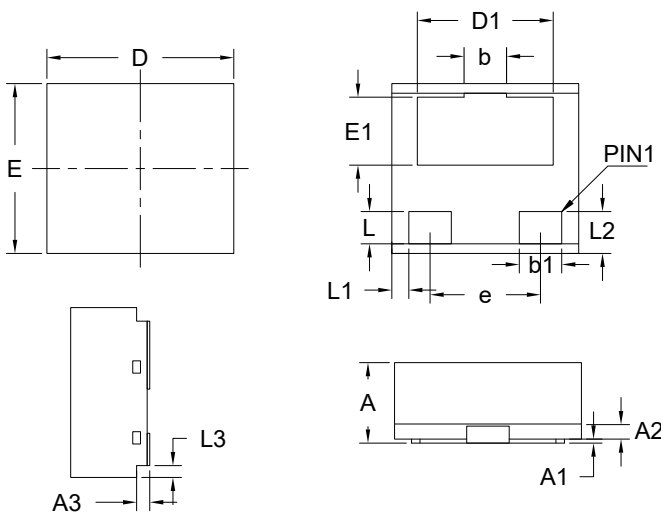

	DIMENSIONS				NOTE
	INCH		MM		
	MIN	MAX	MIN	MAX	
A	0.016	0.020	0.400	0.500	
A1	0.000	0.002	0.000	0.050	
A2	0.004		0.100		MIN
A3	0.005		0.127		MIN
D	0.041	0.045	1.050	1.150	
E	0.037	0.041	0.950	1.050	
D1	0.030	0.033	0.750	0.850	
E1	0.014	0.018	0.350	0.450	
b	0.008	0.012	0.200	0.300	
b1	0.008	0.012	0.200	0.300	
e	0.024	0.028	0.600	0.700	
L	0.006	0.009	0.140	0.240	
L1	0.004		0.100		TYP
L2	0.008	0.012	0.210	0.310	
L3	0.000	0.003	0.000	0.070	

### Suggested Solder Pad Layout

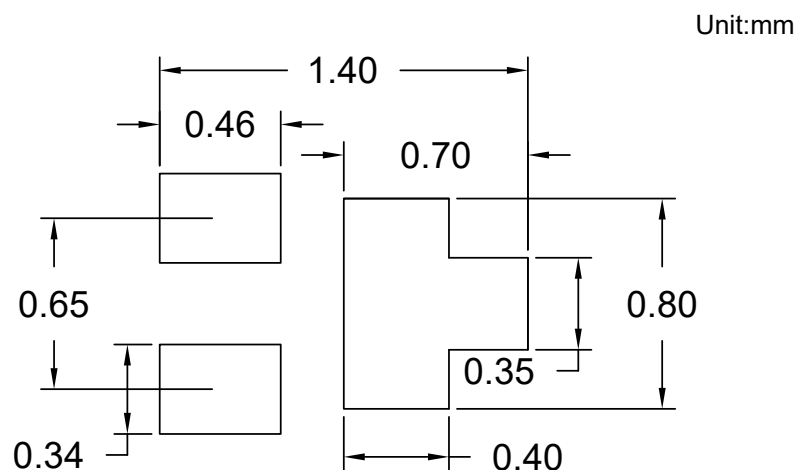

**Notes:**

- 1.The suggested land pattern dimensions have been provided for reference only.
- 2.For further information,please reference document IPC-7351A.

**Packing Quantity**

Package	Tape Width (mm)	Reel Size (inch)	Reel Quantity	BOX Quantity	Carton Quantity
DFN1110-3(SWF)	8	7	10000	100K	400K

Note 1: These are minimum package quantities only. Minimum orders will differ. Contact the factory for more information on minimum order quantities.

Note 2: MCC Tape&reel products meets EIA-481 REV D specification.

**Device Tape Orientation**

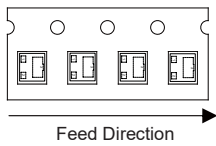
Package	Tape Width (mm)	Tape Orientation
DFN1110-3(SWF)	8	

**Embossed Carrier Tape Specifications**

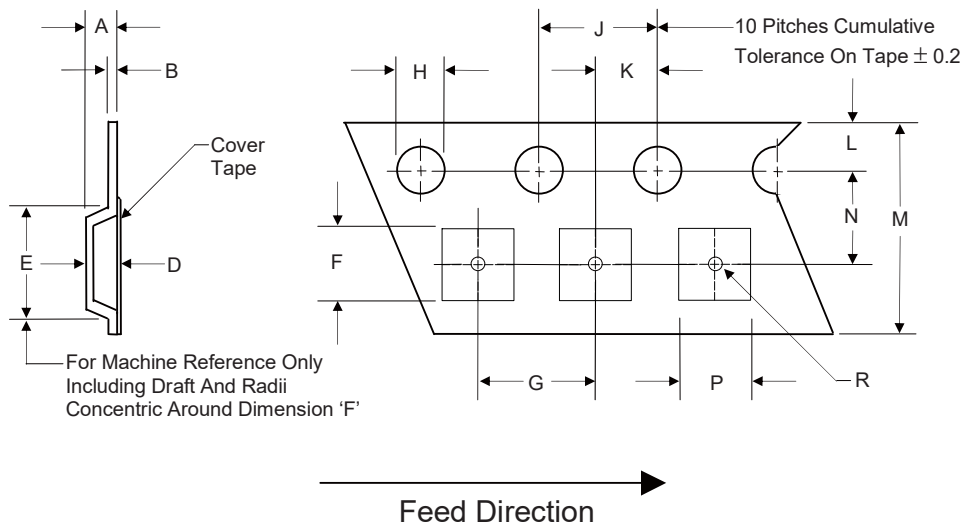

Tape Width	H	L	J	B	D	F	P
8mm	1.5	1.75	4.0	0.25	See Note 3		
(Tolerance)	+0.1/-0	±0.1	±0.1	±0.02			

Tape Width	E	R	N	A	K	M	G
8mm	4.2	0.5	3.5	1.13	2.0	8.0	4.0
(Tolerance)	Max	±0.05	±0.05	±0.05	±0.05	+0.3/-0.1	±0.1

Note 3: D,E,F are determined by constant size. The clearance between the part and the tape cavity must be within 0.05mm min. to 0.50mm max. for 8mm tape.

## Embossed Carrier Tape Specifications



Tape Size	R Min.
8mm	25mm

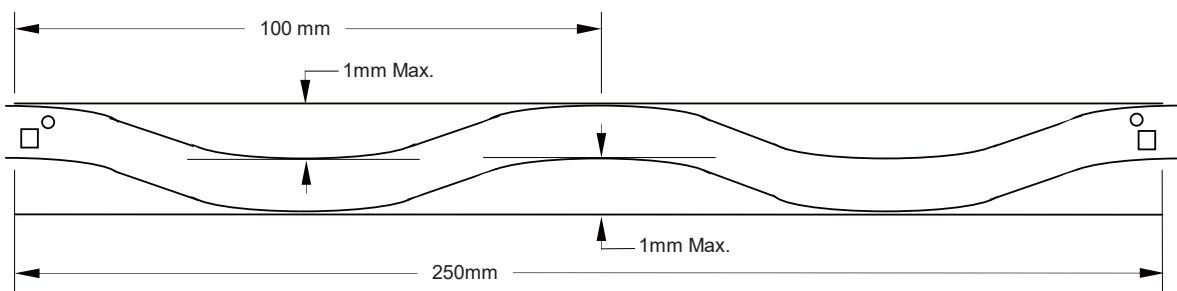

Camber (Top View)

Allowable camber to be 1mm/100mm non-accumulative over 250mm

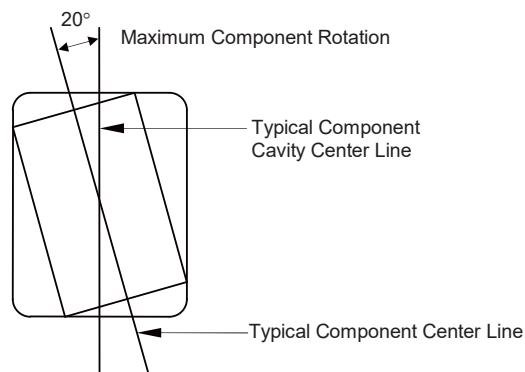

## Start and Finish Specification

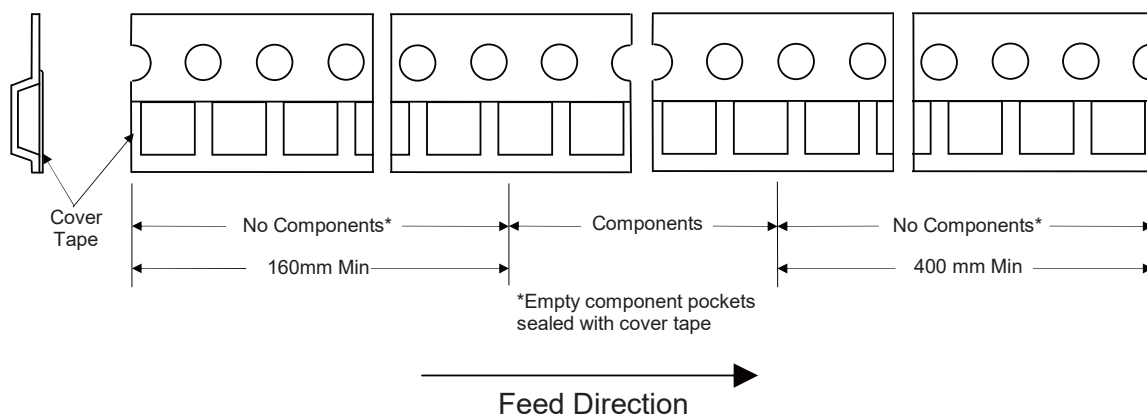

## Surface Mount Reel Specifications

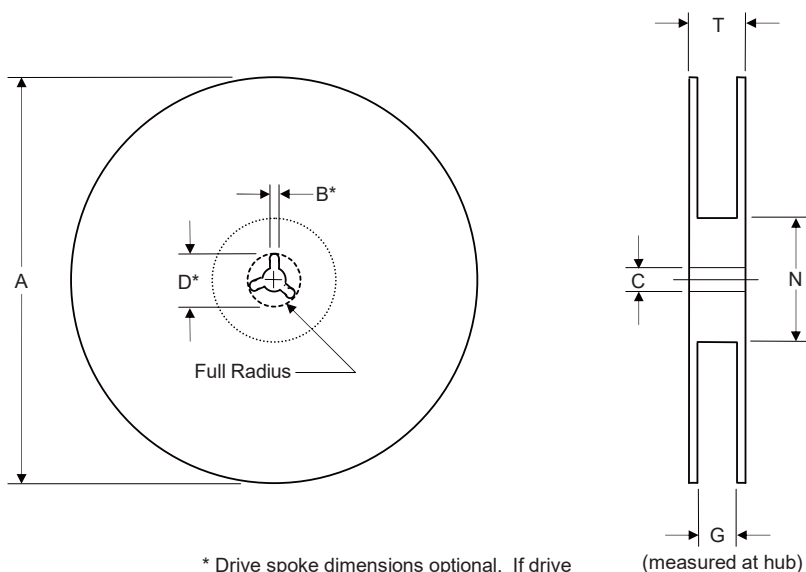

\* Drive spoke dimensions optional. If drive spoke is used then asterisked dimensions apply.

Tape Width	A	B	C	D	N	G	T
8mm	178	1.5	13.0	20.2	55	9.5	12.5
(Tolerance)	±2.0	Min	±0.2	Min	±1.0	±1.0	±1.0

## Dimensions

### Inbox Size

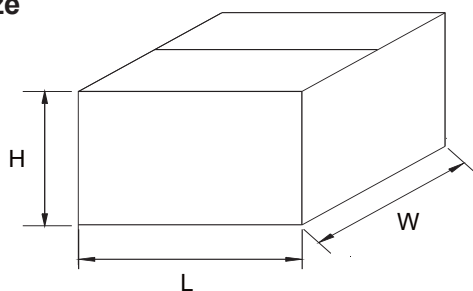

Dimension	Specification(mm typical)	
	General	MBB Bag
L	187	227
W	130	145
H	187	202

### Carton Size

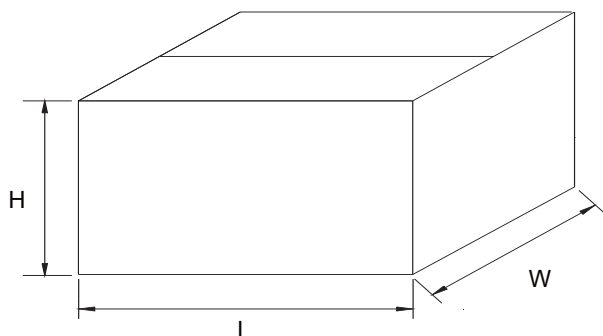

Dimension	Specification(mm typical)	
	General	MBB Bag
L	390	470
W	275	305
H	207	223