

Package Outline

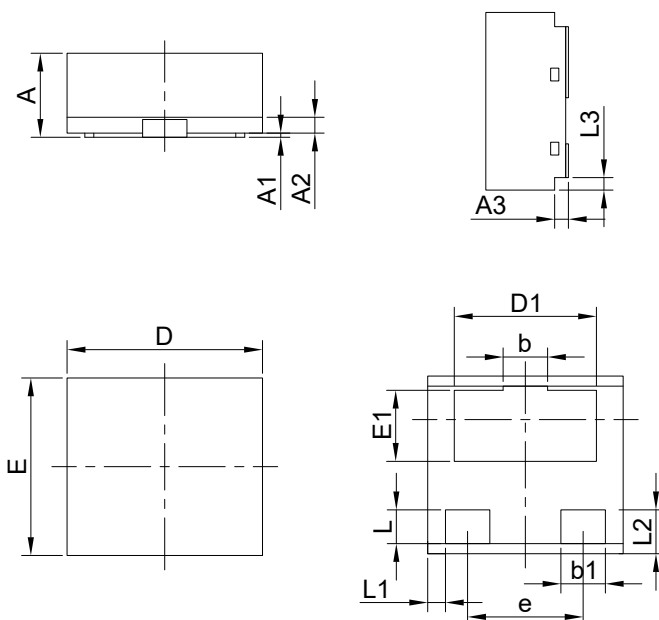

DIM	INCH		MM		NOTE
	MIN	MAX	MIN	MAX	
A	0.016	0.020	0.400	0.500	
A1	0.000	0.002	0.000	0.050	
A2	0.004		0.100		TYP
A3	0.005		0.127		TYP
D	0.041	0.045	1.050	1.150	
E	0.037	0.041	0.950	1.050	
D1	0.030	0.033	0.750	0.850	
E1	0.014	0.018	0.350	0.450	
b	0.008	0.012	0.200	0.300	
b1	0.008	0.012	0.200	0.300	
e	0.024	0.028	0.600	0.700	
L	0.006	0.009	0.140	0.240	
L1	0.004		0.100		TYP
L2	0.008	0.012	0.210	0.310	
L3	0.000	0.003	0.000	0.070	

Suggested Pad Layout

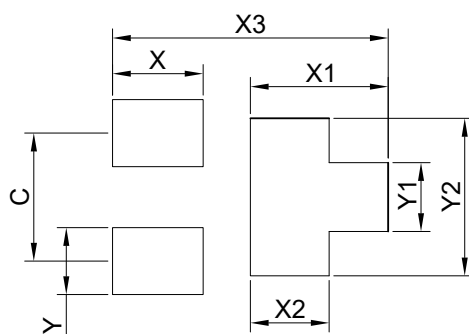

DIM	MM
X	0.46
X1	0.7
X2	0.4
X3	1.4
Y	0.34
Y1	0.35
Y2	0.8
C	0.65

Notes:

1. The suggested land pattern dimensions have been provided for reference only.
2. For further information, please reference document IPC-7351A.